

Part No. D00586

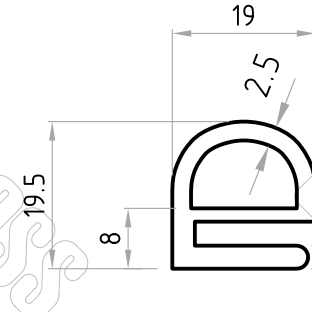

Part No. D00587

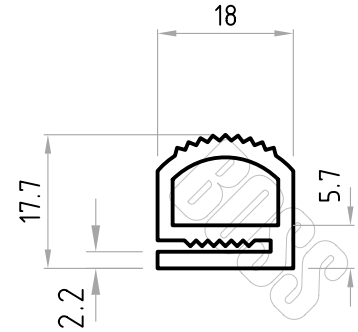

Part No. D01096

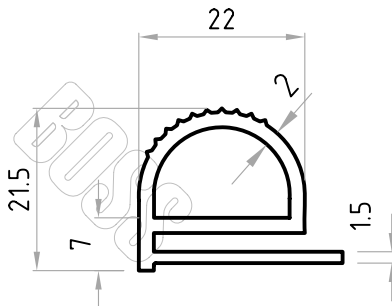

Part No. D00549
Part No. D00550

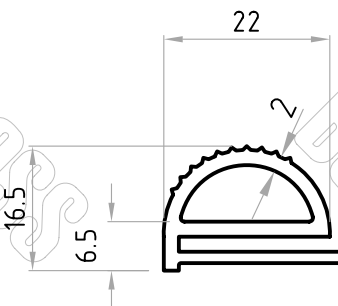

Part No. D00551
Part No. D00552

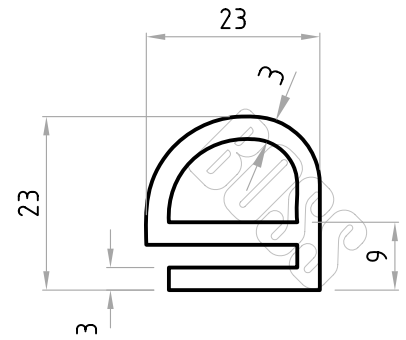

Part No. D02364

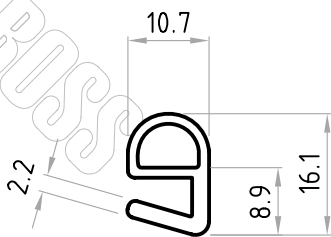

Part No. D02192

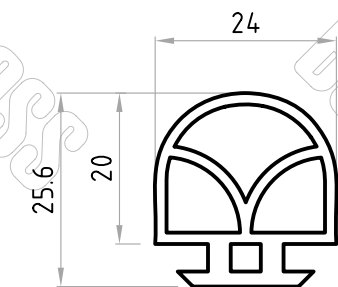

Part No. D02179

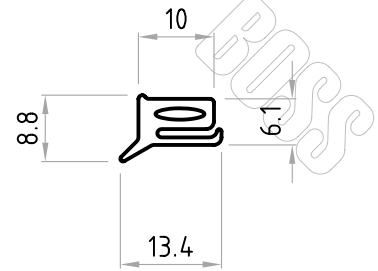

Part No. D03049

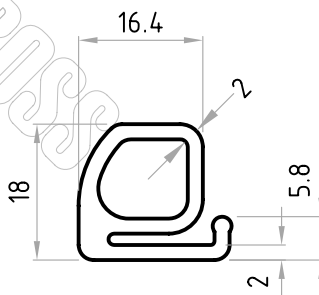

Part No. D02520

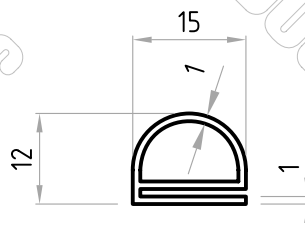

Part No. D02685

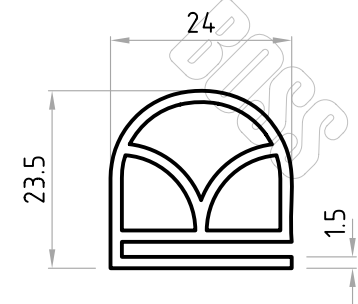

Part No. D02178

* Profile drawings appearing in this section are indicative only. some profiles may be restricted to specific customers, patents and or other limitations. The material displayed on this page may not be reprinted or otherwise reproduced without the express written permission of Boss Polymer Technologies.

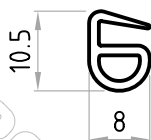

Part No. D03549

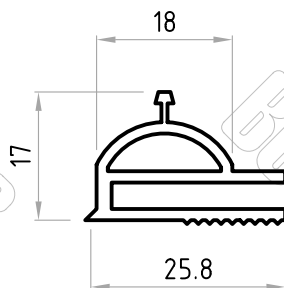

Part No. D02265

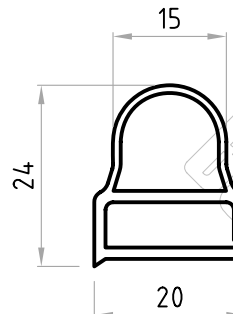

Part No. D02280

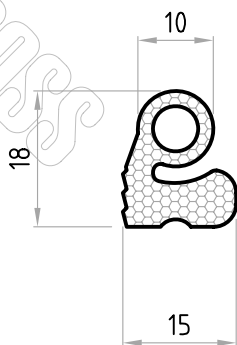

Part No. D02217

* Profile drawings appearing in this section are indicative only. some profiles may be restricted to specific customers, patents and or other limitations. The material displayed on this page may not be reprinted or otherwise reproduced without the express written permission of Boss Polymer Technologies.